

**BL20 Economy Module**  
**8 2-wire Analog Inputs U/I resp. 4 2/3-wire PT/Ni Inputs**  
**BL20-E-8AI-U/I-4PT/Ni**

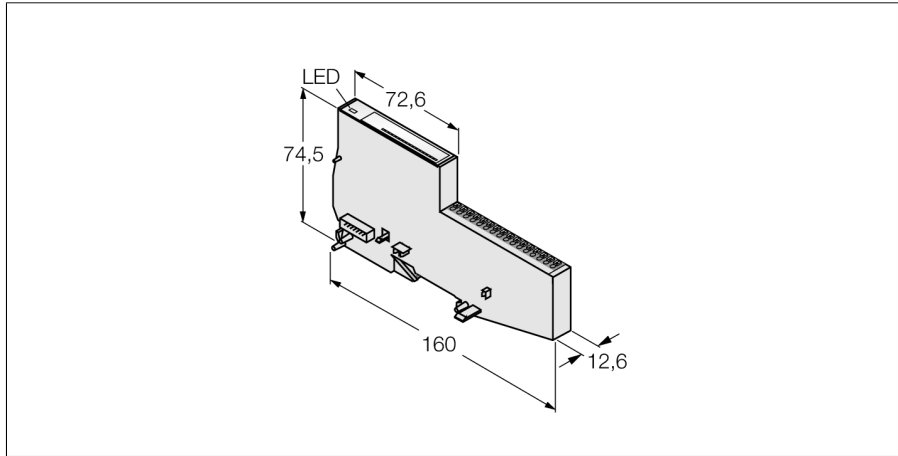

- Fieldbus-independent
- Electronics and connection technology in one housing
- Connectivity: Push-in terminals
- Protection class IP20
- LEDs indicate status and diagnostic
- Electronics galvanically separated from the field level via optocouplers
- 8 analog 2-wire inputs U/I
- Passive input - External supply
- 0 ... 20 mA, 4 ... 20 mA, -10 ... +10 VDC or 0 ... +10 VDC, selectable per channel
- Alternatively: 4PT/Ni inputs (always 2 analog inputs are combined to a PT/Ni 2/3-wire input)

<b>Type designation</b>	BL20-E-8AI-U/I-4PT/Ni
Ident-No.	6827325
<b>Number of channels</b>	8/4
Rated voltage from the supply terminal	24 VDC
Admissible range	18...30 VDC
Nominal current from field supply	≤ 35 mA
Nominal current from module bus	≤ 35 mA
Power dissipation, typical	≤ 1.5 W
<b>Inputs</b>	
Input type	0/4...20 mA, -10/0...10 VDC, Pt100, Pt200, Pt500, Pt1000, Ni100, Ni1000, 0...250 Ω, 0...400 Ω, 0...800 Ω, 0...2000 Ω, 0...4000 Ω
Input resistance	< 62 Ω (current) resp. > 98.5 kΩ (voltage)
Max. input current	current: 50 mA
Max. input voltage	Voltage: -20 VDC < U < 20 VDC
Electrical isolation	electronics for the field level
Output connectivity	Push-in Push-in
<b>Maximum limiting frequency analog</b>	1.5 Hz
Basic fault limit at 23 °C	< 0.2 %
Temperature coefficient	< 200 ppm / °C of full scale
Resolution	16 Bit
Measured-value display	16 bit signed integer 12 bit full range left-justified 12 bit left-justified
Conversion time	< (44 x [ number of actively parametrized channels]) ms
<b>Number of diagnostics bytes</b>	8
Number of parameter bytes	8
<b>Dimensions (W x L x H)</b>	12.6 x 160 x 74.6mm
Approvals	CE, cULus, zone 2, Class I, Div. 2
Operating temperature	0 to +55 °C
Storage temperature	-25...+85 °C
Relative humidity	5 to 95% (internal), Level RH-2, no condensation (at 45 °C storage)
Vibration test	acc. to EN 61131
Shock test	acc. to IEC 68-2-27
Drop and topple	acc. to IEC 68-2-31 and free fall to IEC 68-2-32
Electromagnetic compatibility	acc. to EN 50,082-2
Protection class	IP20













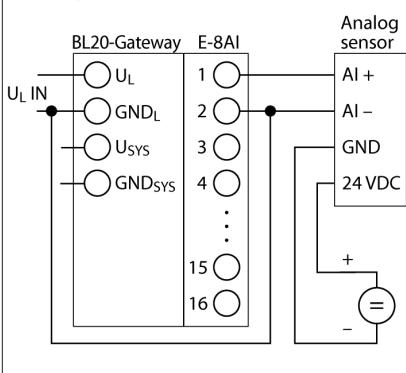





















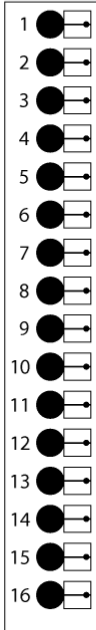
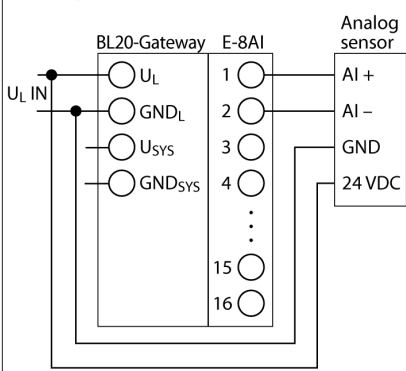
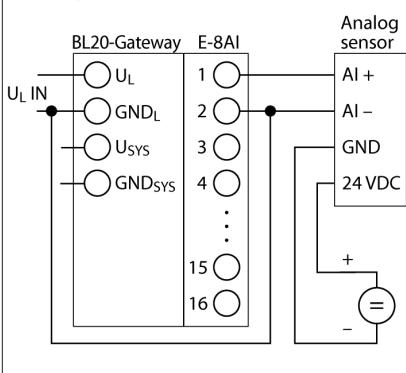





















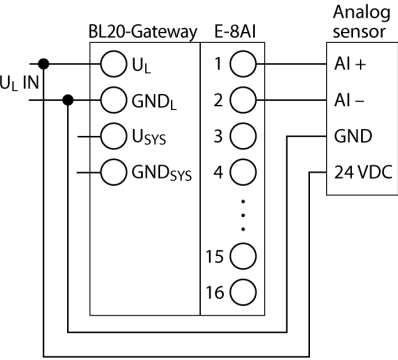
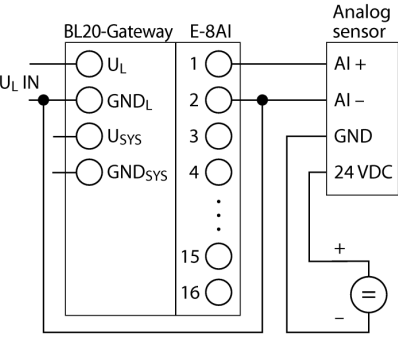
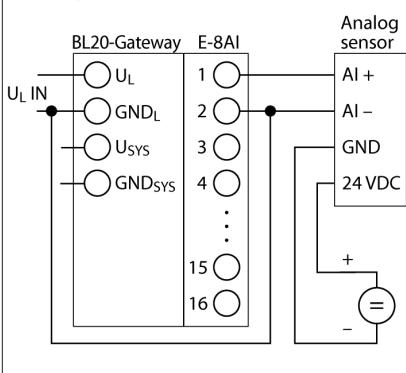











**Functional principle**

Electronics and connection technology are integrated in the housing. A base module is not needed. Economy modules and modules with separate electronics and connection technology can be fitted into a station, provided the base modules feature tension spring connections.

The use of gateways makes economy modules completely independent from the higher level fieldbus.

**BL20 Economy Module**  
**8 2-wire Analog Inputs U/I resp. 4 2/3-wire PT/Ni Inputs**  
**BL20-E-8AI-U/I-4PT/Ni**

**Terminal assignment**

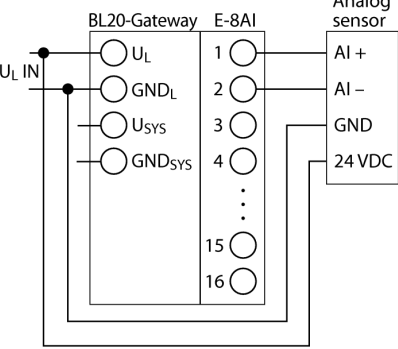
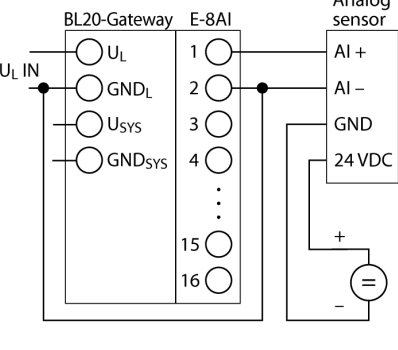
	<p><b>Analog Inputs</b></p> <p>The pin assignment is dependent on the sensor type. Examples of the most common 2- and 4-wire sensors with electric current or voltage signal are listed below.</p> <p><b>Note:</b> Open inputs and/or unused channels should not be programmed in the Pt/Ni or resistance (R) mode, because this may lead to minor measurement errors at adjacent channels. However, if this is necessary, the affected channels must be terminated with a resistance. Thereby the resistance value must be in the programmed measuring range.</p>	<p><b>Pin Assignment</b></p> <table border="0"> <thead> <tr> <th>U/I 2-wire</th> <th>PT/Ni 2-wire</th> <th>PT/Ni 3-wire</th> <th></th> </tr> </thead> <tbody> <tr> <td></td> <td></td> <td></td> <td>1</td> </tr> <tr> <td></td> <td></td> <td></td> <td>2</td> </tr> <tr> <td></td> <td></td> <td></td> <td>3</td> </tr> <tr> <td></td> <td></td> <td></td> <td>4</td> </tr> <tr> <td></td> <td></td> <td></td> <td>5</td> </tr> <tr> <td></td> <td></td> <td></td> <td>6</td> </tr> <tr> <td></td> <td></td> <td></td> <td>7</td> </tr> <tr> <td></td> <td></td> <td></td> <td>8</td> </tr> </tbody> </table>	U/I 2-wire	PT/Ni 2-wire	PT/Ni 3-wire					1				2				3				4				5				6				7				8
U/I 2-wire	PT/Ni 2-wire	PT/Ni 3-wire																																				
			1																																			
			2																																			
			3																																			
			4																																			
			5																																			
			6																																			
			7																																			
			8																																			
	<p><b>4-wire sensor (U/I)</b></p> <p>The sensor and the BL20 <math>U_L</math> fuse are fed from a common source. The sensor and the BL20 <math>U_L</math> fuse are automatically on the same GND potential.</p>	<p><b>Pin Assignment</b></p> 																																				
	<p><b>4-wire sensor (U/I)</b></p> <p>The sensor and the BL20 <math>U_L</math> are fed from different sources. <math>U_L</math> of the BL20 system and AI of the sensor must be on the same GND-potential. For this, <math>U_L</math> and AI must be bridged.</p>	<p><b>Pin Assignment</b></p> 																																				

**BL20 Economy Module**  
**8 2-wire Analog Inputs U/I resp. 4 2/3-wire PT/NI Inputs**  
**BL20-E-8AI-U/I-4PT/NI**

**2-wire sensor (U/I)**

The sensor and the BL20  $U_L$  fuse are fed from a common source.  
 The sensor and the BL20  $U_L$  fuse are automatically on the same GND potential.

**Pin Assignment**

